

Technical Specifications

SAFEPOWER-EVO-HF



10/15/20/30/40 kVA three-phase input/three-phase output

Contents

..1..	OBJECTIVE	3
..2..	SYSTEM DESCRIPTION	3
..3..	REFERENCE STANDARDS	4
..4..	APPLICATIONS	5
..5..	CONFIGURATIONS	6
..6..	UPS DESCRIPTION	8
	> 6.1 PFC Converter (Zero Impact Source)	9
	> 6.2 Battery Charger (Battery Care System)	11
	> 6.3 Inverter	13
	> 6.4 Static Switch (Automatic Bypass)	15
..7..	CONTROL PANEL	16
..8..	ISOLATING SWITCHES	18
..9..	COMMUNICATION	18
	> 9.1 Emergency Shutdown (R.E.P.O.)	21
	> 9.2 External Synchronisation	21
	> 9.3 Monitoring and Control Software	22
	> 9.4 Configuration Software	22
..10..	UPS CABINET	24
..11..	OPTIONS	25
	> 11.1 Communication	25
	> 11.2 External Battery Temperature Sensor	26
	> 11.3 External Maintenance Bypass	26
	> 11.4 Battery Cabinets	27
	> 11.5 Additional Battery Charger	28
	> 11.6 Optional Transformers	29
	> 11.7 Separate Line Input	32
..12..	ENVIRONMENTAL CONDITIONS	33
..13..	TECHNICAL DATA 10–40 KVA three–phase output	33

1 – OBJECTIVE

These specifications define the technical characteristics of the **SAFEPOWER-EVO-HF** uninterruptible power supply (UPS). The UPS is designed to supply a clean and stable electrical supply, irrespective of the condition of the mains or an alternative power supply.

The **SAFEPOWER-EVO-HF** series of UPS is designed and manufactured by Siel UPS, a leader in this field with a range of products from 350VA to 800kVA, and over 25 years of experience in power protection.

For more information please visit our website at: www.sielups.com.

2 – SYSTEM DESCRIPTION

The **SAFEPOWER-EVO-HF** UPS is available in 10-15-20-30-40 kVA On Line double conversion technology.

SafepowerEvo-HF meeting the VFI-SS-111 classification defined by IEC EN 62040-3.

SAFEPOWER-EVO-HF is designed to protect critical industrial and Information Technology (IT) systems with the following features:

- a) Zero Impact Source
 - low input current distortion - as low as 3% and with a 0.99 input power factor;
 - Power Walk-In and start-up delay to reduce generator oversizing; these features also help to guarantee supply compatibility where available mains power is limited.
- b) Battery Care System
 - two voltage level recharge according to the IU characteristic, in A-C
 - temperature compensating recharge voltage;
 - suitable for the charging of extended back-up battery sets with additional charger options;
 - Battery test function to detect potential battery deterioration
 - Cyclical recharge
 - Recharging the "commissioning charge".
- c) Inverter thermal oversizing in order to guarantee 110% overload (0.8pF) without time restrictions;
- d) Capability to power loads with $\cos \phi$ from 0.9 inductive to 0.9 capacitive, without active power (kW) reduction;
- e) High performance design achieving a system efficiency of up to 96.5%;
- f) Backfeed protection;
- g) Multi-function case design to allow:
 - the installation of an internal transformer option
 - Compatible with the addition of an optional battery charger.

The **SAFEPOWEREVO-HF** series consists of the following models:

MODEL	DESCRIPTION
Safepower-Evo10-HF	10kVA three-phase input/three-phase output UPS
Safepower-Evo15-HF	15kVA three-phase input/three-phase output UPS
Safepower-Evo20-HF	20kVA three-phase input/three-phase output UPS
Safepower-Evo30-HF	30kVA three-phase input/three-phase output UPS
Safepower-Evo40-HF	40kVA three-phase input/three-phase output UPS

The MST../MSM...cabinet versions, measuring 1320x440x850mm (HWD), are also available for optimal solutions when medium to long term runtimes are required.

3 – REFERENCE STANDARDS

Siel UPS operates a Quality Management System certified to ISO 9001/2000 (Certification No. 005SGQ01) covering all company functions from design and manufacture to after sales services.

In addition, the UPS meets the VFI-SS-111 classification (according to EN 62040-3) and complies with the following specific standards for UPS:

- **IEC EN62040-1**: Static uninterruptible power supplies (UPS): general and safety provisions;
- **IEC EN62040-1-1**: Static uninterruptible power supplies (UPS): general and safety provisions for operator-accessible areas;
- **IEC EN 62040-2**: Electromagnetic compatibility (EMC) requirements category C2
- **EN 62040-3**: Methods of specification of performances and test provisions;

The **SAFEPOWEREVO-HF** series also satisfies the following general standards, where applicable:

- **IEC 60529**: Degree of protection provided by enclosures;
- **IEC 60664**: Insulation for low-voltage equipment;
- **IEC 60755**: General Requirements for Residual Current Operated Protective Devices;
- **IEC 60950**: General safety provisions for "Information Technology" equipment;
- **IEC 61000-2-2**: Electromagnetic compatibility immunity;
- **IEC 61000-4-2**: Electrostatic discharge immunity test;
- **IEC 61000-4-3**: Radio frequencies, electromagnetic immunity test;
- **IEC 61000-4-4** : Transitory overvoltage immunity test;
- **IEC 61000-4-5** : Overvoltage immunity test;
- **IEC 61000-4-11**: Voltage dips, short interruptions and voltage variations immunity test.
- **IEC 61000-3-12**: Harmonic current emissions (for equipment with rated current > 16 A ≤ 75)

European Directives:

LV 2006/95/EC

Low voltage Directive: contains provisions relating to equipment safety and imposes the EC marking obligation from 1/1/97.

EMC 2004/108/EC

Electromagnetic compatibility directive: contains provisions relating to UPS immunity and emissions in its installation environment and imposes the EC marking obligation from 1/1/96.

4 – APPLICATIONS

SAFEPOWER-EVO-HF UPS are suitable for applications requiring critical load protection including:

LAN, Server and Datacenters: the 0.9 output power factor ensures greater active power availability for efficient UPS loading.

e-business and Telecommunications: parallel operation means that the installed UPS size can be increased (up to 6 units) to keep pace with the growth of the organisation.

Industrial processes and electro-medical systems: the UPS is designed to protect a range of loads, from industrial processes to electro-medical applications. This has been achieved through careful load analysis at the design stage of the **Safepower-Evo-HF** project, to ensure the following characteristics:

- optimum input technical characteristics with zero impact on the power supply source
- high short circuit and overload capacity
- high battery recharge capacity with the option to use a variety of battery types (sealed valve regulated and open-vented) for long back-up times.

Emergency systems: the UPS can be configured to operate in any one of four operating modes to comply with EN 50171 (the Centralised Power Supply Systems) standard:
 In addition to the type of battery, the autonomy and recharge times and in accordance with EN 50171 standard, four different operating modes can be chosen to meet the needs of the plant:

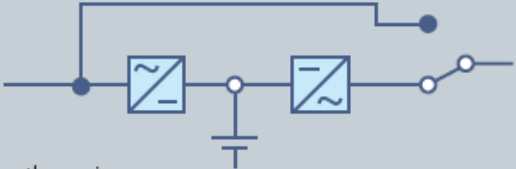
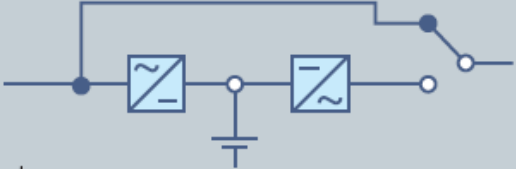
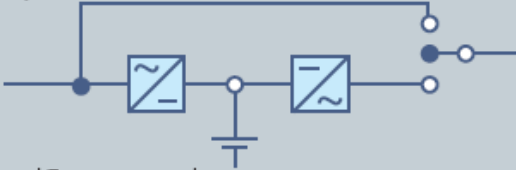
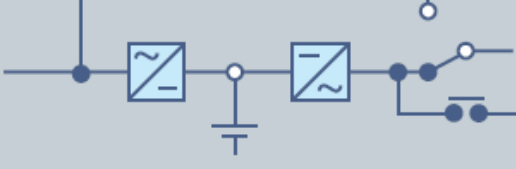
Operating modes (EN50171)	SAFEPOWEREVO-HF Configurations
<p>1. Always powered</p> 	<p>The UPS operates in the following mode: ON-LINE (See chapter 6 "Ups descriptions")</p>
<p>2. Powered from the mains</p> 	<p>The UPS operates in the following mode: ECO-MODE (See chapter 6 "Ups descriptions")</p>
<p>3. Emergency only</p> 	<p>The UPS operates in the following mode: STAND BY-OFF (See chapter 9.4 "Configuration Software")</p>
<p>4. Always powered/Emergency only</p> 	<p>The UPS operates in the "ON LINE" MODE by using the POWERSHARE socket (Option) (see the operating manual)</p>

5 – CONFIGURATIONS

The UPS can be installed as a single, stand-alone UPS and this format is most commonly used for relatively straight forward installations. This can be expanded up to 6 units (4 units in the 3/1 version) in order to meet load power demands or to introduce a level of redundancy.

Parallel configuration

Up to 6 UPSs can be connected in parallel to increase the power of the uninterruptible power system (power parallel) or to enhance its reliability (redundant parallel).
 The system is defined as "redundant parallel" when the stoppage of one or several UPSs does not determine the loss of the power supply.

All the UPSs power the load simultaneously with automatic sharing of the current.

The units exchange information on the operating status and the sync signals by means of the RS485 connections in loop with dual redundancy. This means that even in the event of the accidental interruption of both connections, only the UPS affected by this interruption cuts itself off, while the other one continues to operate without any interference.

The “**Hot System Expansion**” feature means that a new UPS can be added to the system while the other units are on-line and powering the load from the inverter.

The integrated UPS will configure itself automatically with the system data without any disturbance to the load.

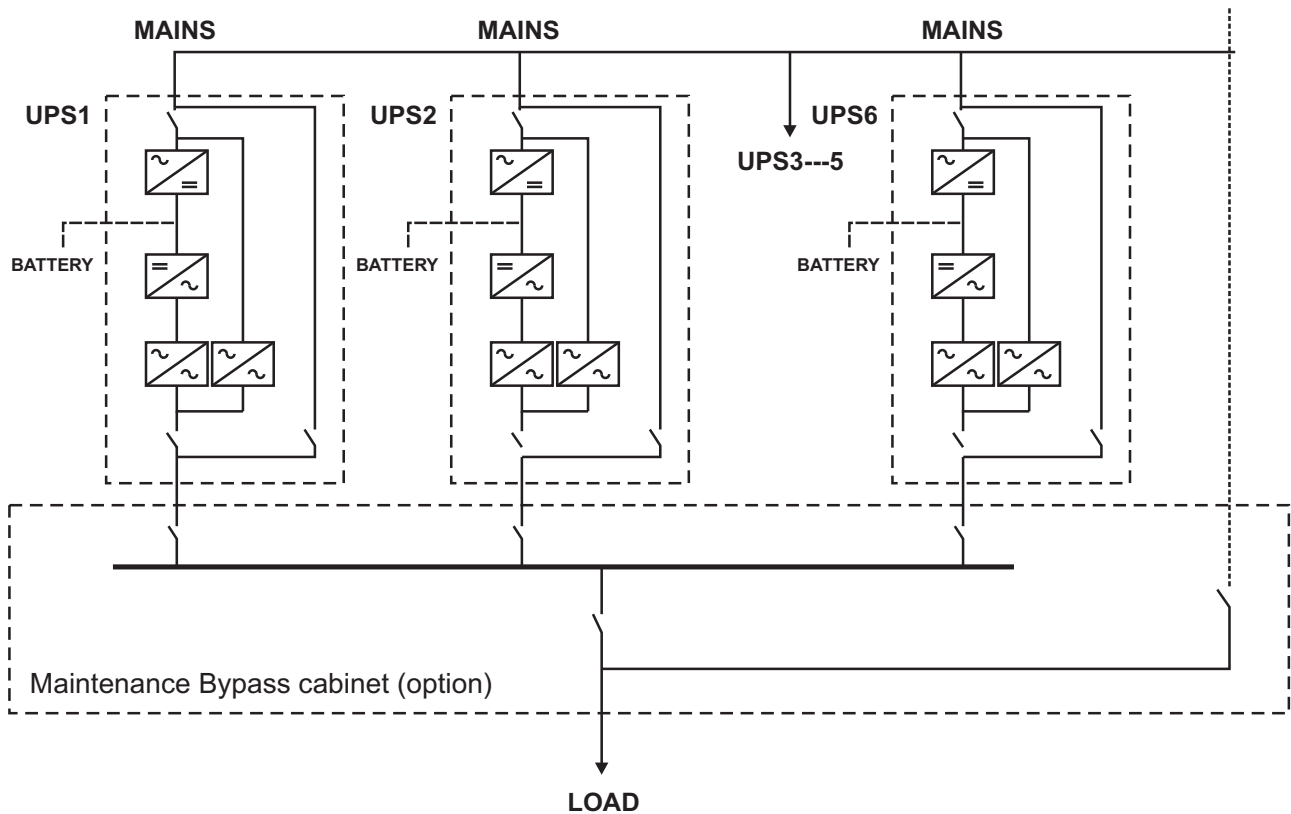

NOTE: for realizing a parallel configuration where is required a transformer connected downstream each single UPS please contact the manufacturer in advance

6 – UPS DESCRIPTION

The UPS can be operated in four main operating modes: ON-LINE, FREQUENCY CONVERTER, ECO and SMART ACTIVE and in their main variants described in paragraph 4 (Emergency systems).

Mode: ON-LINE

Normal Operation: the rectifier, drawing power from the mains power supply, supports the Inverter and charges the batteries; the load is powered by the Inverter which provides a clean and secure supply, synchronised to the bypass supply.

Emergency Operation: if the mains power supply wanders outside the permitted input range (voltage and frequency), the rectifier is shut down and the Inverter is automatically powered by the battery set for the preset back-up time and without disruption to the load. When the mains power supply returns, the rectifier gradually starts up, charging the batteries and eventually powers the Inverter.

Operation from By-pass: if an Inverter overload exceeds permitted limits (or is manually shutdown), the load automatically transfers to the emergency bypass via the static switch and without disruption to the load.

Mode: FREQUENCY CONVERTER

The UPS can be configured as a frequency converter (with "UComGP"), therefore when the input frequency is 50Hz the output frequency can be 60Hz and vice versa. The UPS can work in frequency converter mode with or without the batteries (must be set up with "UComGP").

Mode: ECO

The load is normally powered from the emergency bypass supply and the rectifier maintains battery charge. When the mains power supply wanders outside the permitted input range, the load is automatically transferred to the output of the Inverter until the mains power supply returns within range.

This mode is useful when powering loads that do not require the regulated no-break supply from the Inverter and allows the system to achieve an efficiency up to 98%.

Mode: SMART

When the UPS is configured to operate in SMART ACTIVE mode, it automatically selects whether to operate in ON-LINE or ECO mode.

The decision is made based on statistical calculations performed by the UPS and based on the quality of the mains and bypass supplies: if the latter remains suitable for a certain period, the unit selects ECO mode, otherwise it remains in ON-LINE mode.

The **Safepower-Evo-HF** block diagram is as follows:

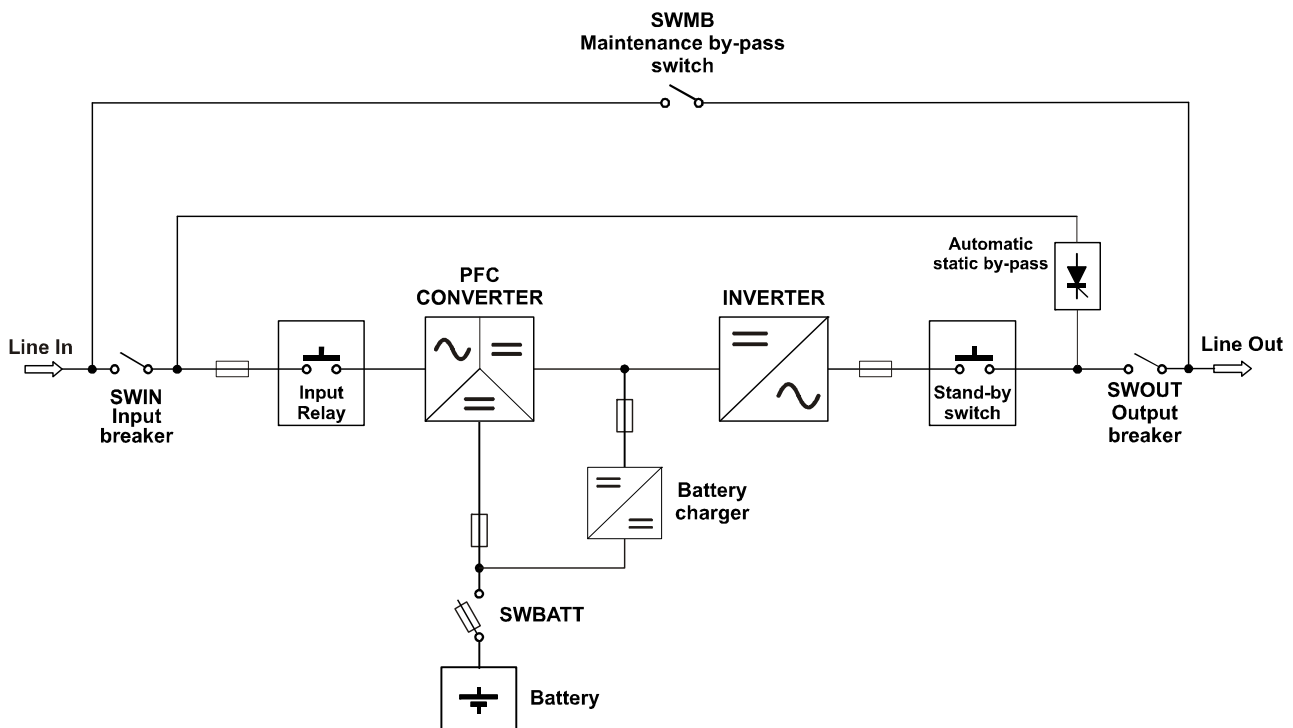

> 6.1 PFC CONVERTER (ZERO IMPACT SOURCE)

The PFC Converter converts the AC voltage into a DC supply to power the Inverter; if the mains or alternative power supply fails, the Converter will raise the battery voltage to a value suitable with which to power the Inverter. The PFC control technology using Digital Signal Processing (DSP) microprocessors and IENT power semiconductors to achieve a low impact on the power supply source, low harmonic distortion and high input power factor. A zero impact on the supply source is achieved due to the following characteristics:

- **Negligible Input Harmonics:** upstream generators and transformers (including distribution) can be reduced due to the negligible input harmonic distortion of < 3% and high input power factor > 0.99.
- **Delayed switching of UPS -t0-T1 (Power Walk In Start Delay):** when the mains power supply returns, the UPS delays switching of the input stage for a period of time that can be set between 0 and 255 seconds (5 seconds standard). This function is particularly useful when the mains power supply returns after an interruption (or when the generator set is started) and the source must supply various UPS or, more typically, multiple users.

- **Progressive rectifier start-up -T1-t2 (Power Walk In Duration):** when the mains power supply returns, absorption of the mains power supply progressively reaches the nominal value within a time period that can be set from 5 to 30 seconds. This function is normally disabled.

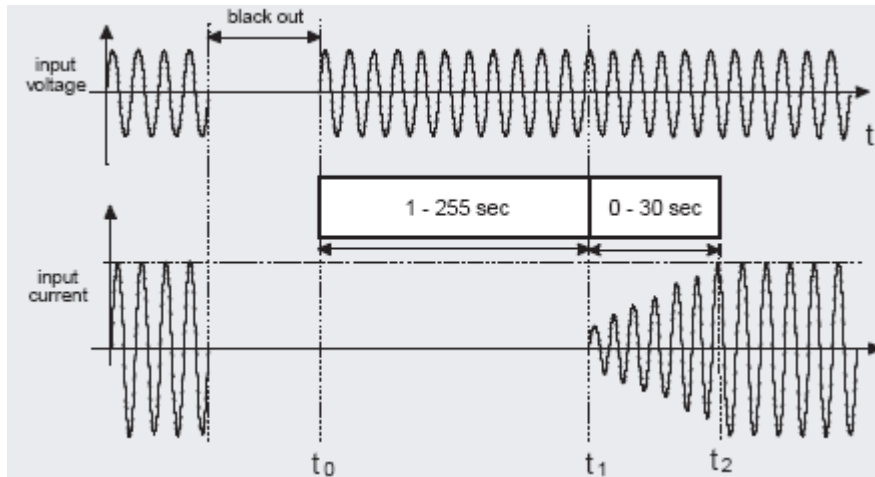

> 6.2 BATTERY CHARGER (Battery Care System)

The "Battery Care System" is a set of functions arranged to help extend the working life the battery set and optimise its performance.

- a) **Battery recharging:** the UPS can be used with sealed lead batteries (VRLA), AGM, open-vented and NiCd batteries. According to the type of battery used two recharge methods are available:

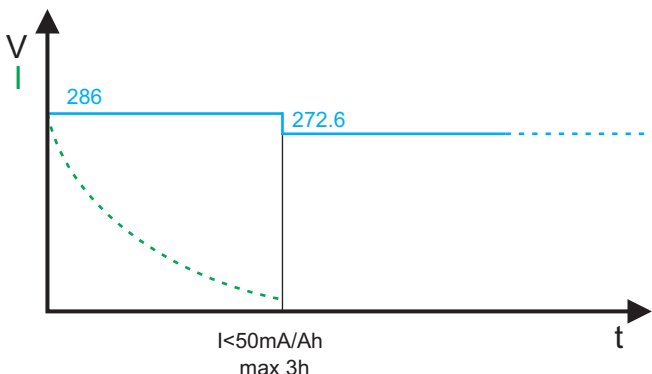
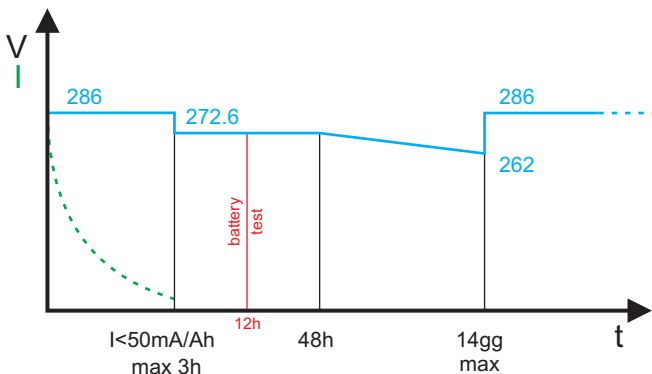
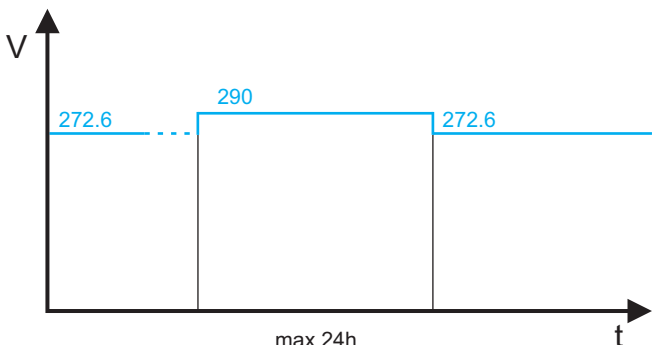
Recharging modes (selectable by "UComGP")	SAFEPOWEREVO-HF configurations
	<p>Floating (standard configuration): the charge state of the battery is continuously monitored; when the mains power supply is present, the batteries are charged at a preset voltage level and limited current relative to the recharge time required and the capacity of the battery itself.</p>
	<p>Two-level recharge (configurable): this recharge is at limited current with two levels of voltage. In the first instance, the process uses a quick charge voltage, whilst in the second stage a float charge. This type of charging is mainly used with open-vented batteries or other types when an accelerated recharge time is required.</p>
	<p>Cyclical recharge: this recharge is sometimes recommended by battery manufacturers to prolong the battery life. It consists of battery charge and discharge cycles as indicated in the diagram.</p>
	<p>"Commissioning charge": this charge method is useful every time new batteries are installed in the UPS. By increasing the voltage to 290 volts for a maximum of 24 hours, perfect equalisation of the battery charge is assured, thus guaranteeing a uniform discharge and wear of the battery monoblocks.</p>

The various recharge methods and the preset voltage values are defined using “UComGP”. The presence of the external temperature sensor option will activate compensation of the voltage depending on the temperature with the battery backup voltage (272V for 20 battery blocks)

- b) **Battery test:** during normal operation the battery is automatically tested at regular intervals. The battery test can also be manually activated. The test is performed to ensure a limited battery discharge and impact on overall life expectancy. If the test returns a negative result a warning is displayed on the UPS panel (or remote panel, if installed).
- c) **Protection against slow discharges:** for long runtimes and low load discharges, the end of discharge voltage is raised to approximately 1.8V/eI as recommended by the battery manufacturers to avoid a deep discharge state.
- d) **Ripple current:** recharge ripple current (residual AC component) is one of the most important causes of poor battery reliability and reduced operating life. The UPS battery charger is a high-frequency design with a negligible level of ripple current,
- e) **Battery recharge limit current:** The battery recharge current is limited to a prefixed value of $C_{nom}/8$ (i.e. 12.5% C_{nom})
- f) **Cold-Start:** This feature allows the Inverter to be switched on and the load to be powered by the battery, when the mains power supply is not present.
- g) **UPS without batteries:** the UPS must always be operated with the batteries connected; if they are not connected alarms will be generated and the UPS will not be able to perform to specification.

> 6.3 INVERTER

The DC/AC Converter (Inverter) converts the direct current into a stabilised sinusoidal alternating current to power the load. When the UPS is in ON-LINE mode, the load is always powered by the Inverter.

The Inverter is an IGBT (Isolated Gate Bipolar Transistor) based three-phase design; the IGBT is a transistor that allows high commutation frequencies (> 18kHz) and, as a result, the Inverter provides a high quality output voltage, with low noise levels and high operating efficiency. In addition, the DSP microprocessor controls, guarantee static and dynamic performance under any operating condition:

Voltage adjustment

The output voltage can be adjusted using the independent phase control and DSP microprocessor; this enables a better static and dynamic response. In detail:

- a) **static condition:** the Inverter output voltage remains within $\pm 1\%$ for all variations of the input voltage within the accepted limits;
- b) **dynamic condition:** for load variations from 0 to 100%, the output voltage remains within $\pm 3\%$, (within the values defined by class 1 of the EN 62040-3 standard).

Frequency adjustment

The Inverter output frequency is generated autonomously by an internal oscillator, in synchronisation with the bypass supply. Frequency stability is operating condition dependent:

- a) **Frequency stability**
 - a. With mains power present: the internal oscillator follows any frequency variations in the bypass supply and in relation to the preset value - normally $\pm 5\%$ (configurable from $\pm 0.25\%$ to $\pm 10\%$).
 - b. With no supply present: the Inverter autonomously generates the frequency of the output voltage with a stability of $\pm 0.01\%$.

- b) **Frequency variation speed**

The maximum Inverter output frequency variation (to lock to that of the bypass supply) is 1Hz/s (adjustable from 0.5 to 2Hz/s).

Distortion of the output voltage

Inverter output waveform distortion with a linear load is maintained within $\pm 1\%$. Within a non-linear load, as defined by the EN 62040-3 standard, output voltage distortion does not exceed $\pm 3\%$.

Overload

The inverter is sized to provide a power overload for a limited length of time (see the limits indicated in the **Technical specifications table**.)

When the time period or power limits are exceeded, the load is transferred to the bypass supply.

Short circuit capacity

If a short circuit occurs whilst the UPS is operating from the batteries, the Inverter will carefully analyse the output voltage and current in order to distinguish if the short circuit is genuine or an overload.

- During battery operation (mains power supply failure) the Inverter can supply a current limited to 150% for 500ms.
- When the mains power supply is present, the Inverter will switch to bypass supplying a current limited to for 500ms.

The table below recommends the sizing of the various protection devices located downstream of the UPS in order to guarantee their selectivity even in the event of a power failure:

Output protections (values recommended for selectivity)		
	Safepower-Evo10/15/20-HF	Safepower-Evo30/40-HF
rapid fuses (GI)	In (Nominal current)/7	In (Nominal current)/7
Magnetothermal switches (Curve C)	In (Nominal current)/7	In (Nominal current)/7
Ultra-rapid fuses (GF)	In (Nominal current)/2	In (Nominal current)/3

Output voltage symmetry

Under all conditions, output voltage symmetry is maintained within $\pm 1\%$, for balanced loads and $\pm 2\%$ for unbalanced loads of 100% (e.g. one phase with nominal load, the other two with no load).

Phase shift angle

The three-phase Inverter output voltages have a guaranteed phase separation angle of $120^\circ \pm 1^\circ$ for balanced loads and 100% for unbalanced loads.

Performance of a 3-phase Inverter with reactive loads

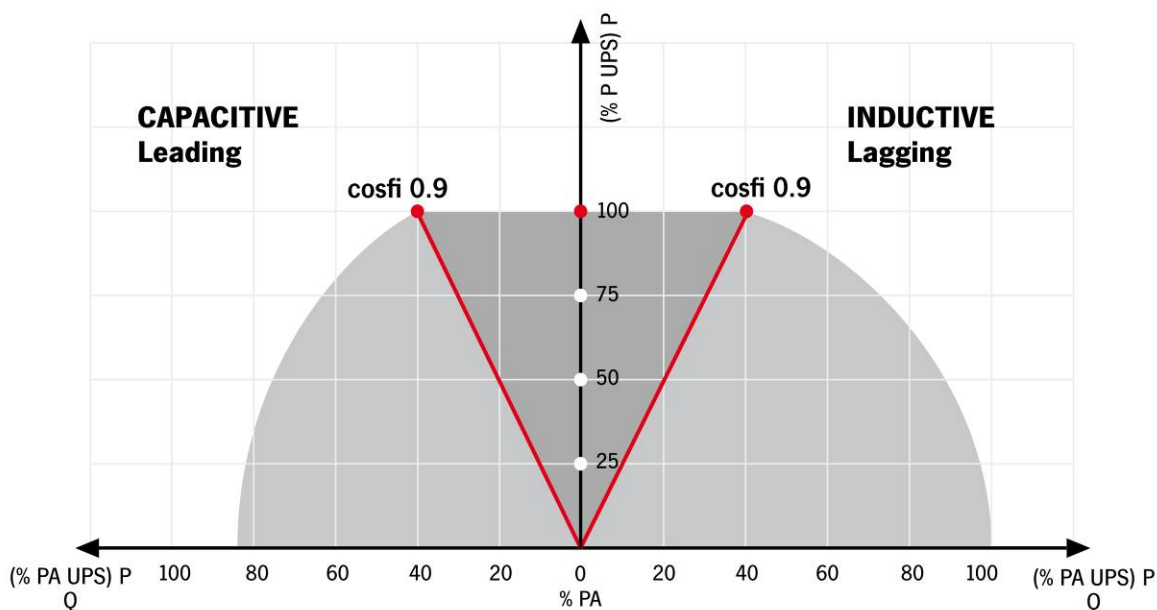

> 6.4 STATIC SWITCH (*Automatic Bypass*)

A static switch is an electronic device that can automatically transfer the loads connected to the UPS to the bypass supply in an emergency for example when:

- a) the Inverter is shut down manually;
- b) Inverter overload limits are exceeded;
- c) internal over temperature limits are exceeded;
- d) the Inverter fails;
- e) DC voltage goes outside the permitted range.

If at the time of switchover, the inverter voltage is not synchronised with that of the auxiliary power supply, the transfer will take place with a delay of around 20ms; in consideration of the various types of loads, this delay can be set with "UComGP" to 10ms or the switchover can be inhibited if there is no synchronism.

Emergency Supply Voltage

Transfer to the emergency supply only takes place if the voltage and the frequency are considered 'suitable' for the load and the limits for transfer can be set on-site by the UPS user.

- Voltage range: $\pm 10\%$ (settable from -20% to $+15\%$);
- Frequency range: $\pm 5\%$ (settable from $\pm 0.25\%$ to $\pm 10\%$)

Overload

The static switch has no over voltage protection devices to guarantee maximum continuity. Overload protection is provided by protective devices within the overall installation to ensure UPS compatibility.

The UPS static switch is sized to support the following overload periods:

- 110% permanently
- 133% for 60 minutes
- 150% for 10 minutes
- >150% for 2 seconds

Under short circuit conditions, the UPS will prevent transfer to bypass for 0.5 seconds; thyristors with $I_{2t}=11250A2s$.

Redundant Auxiliary Power Supply for the Automatic Bypass

The UPS is equipped with a redundant auxiliary power supply to allow the automatic bypass to function even if the main power supply has failed.

If the UPS fails in addition to the main power supply, the load is powered through the automatic bypass. The multi processor card and control panel are not powered, and for this reason, all LEDs and the display are off.

7 – CONTROL PANEL

The control panel consists of a graphical display, 6 visual warning LEDs and 4 function keys.

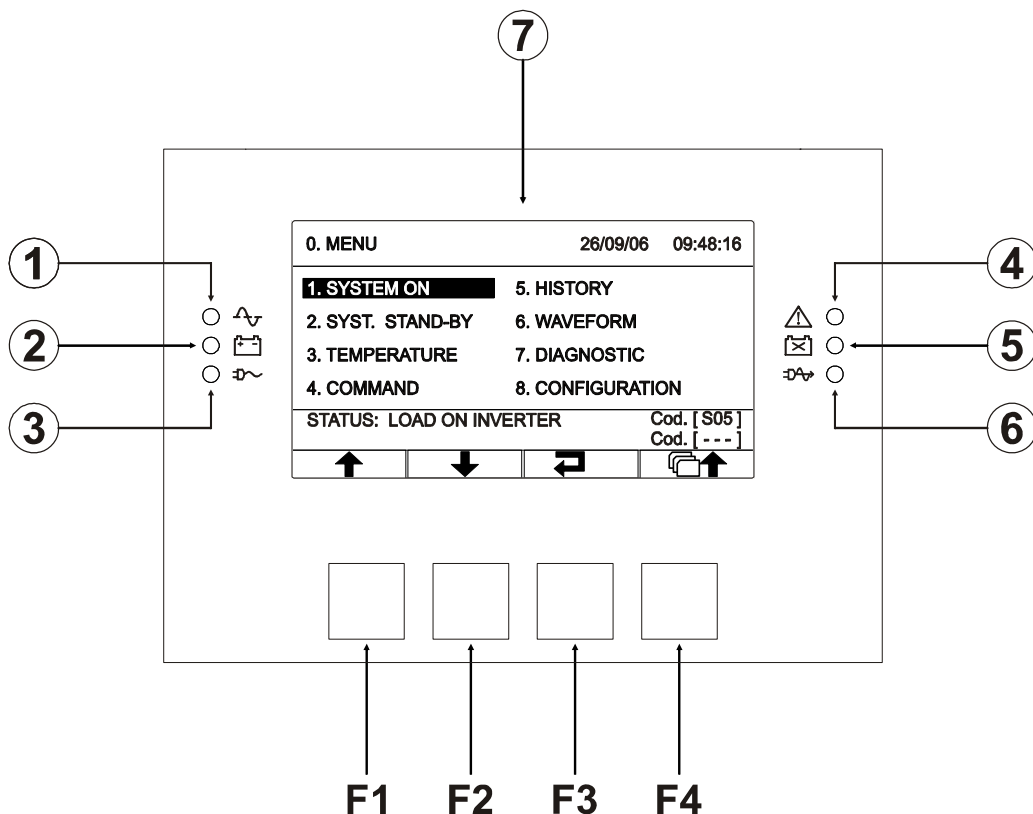

- ① LED for mains operation
- ② LED for battery operation
- ③ LED for load on bypass
- ④ LED for stand-by/alarm
- ⑤ LED for replace batteries
- ⑥ LED for ECO mode
- ⑦ Graphical Display

F1, F2, F3, F4=FUNCTION KEYS. The function of each key is illustrated in the lower part of the display and varies according to the menu.

Messages are available in the following languages: Italian, English, French, German, Spanish, Polish, Russian and Chinese.

At the centre of the control panel there is a wide-area graphical display providing a detailed real-time overview of the UPS operational state. From the control panel the user can switch the UPS on/off, read electrical measurements - mains, output, battery, etc, and set the main operational parameters.

The display is divided into four main areas, each with a specific function:

1 GENERAL INFORMATION

An area permanently showing the date and time and according to the level of display, either the UPS model or the title of the menu active at that time.

2 DATA DISPLAY/NAVIGATION MENU

The main area of the display showing key UPS measurements (constantly updated in real-time). The user can also select and view various menus using the appropriate function keys. After selecting the required menu, this part of the display shows one or more pages containing all the data relevant to that menu.

3 UPS STATE / ERRORS – FAILURES

An area in which the UPS operating state is shown. The first line is always active and constantly displays the state of the UPS at any given time; the second line is active only if an error and/or failure of the UPS occurs and shows the type of error/failure found. Each line on the right shows the code corresponding to the current event.

4 EVENT LOG

An area showing chronological events recorded (supply voltage out of range, high temperature, overload, etc.) and alarms. The log records 960 events in FIFO (First In First Out) mode and the string contains the following information: Event Code, Event Description, Date and Time.

Data is displayed through the graphical display using the scroll keys; the log can be downloaded in TXT format using the **UComGP** configuration software.

5 KEY FUNCTIONS

An area divided into four sections, one for each of the function keys. According to the menu active at any time, the display will show the corresponding function key in the appropriate box.

When an alarm appears an audible warning will sound.

Measurements

- Input voltage and frequency
- By-pass voltage and frequency
- Output voltage, current and frequency
- Output power (VA, W and %)
- Output peak current
- Battery voltage
- Battery charge current
- Internal temperature (control logic, power modules, battery charger, internal batteries)
- External battery temperature
- Back-up time

8 – ISOLATING SWITCHES

The UPS is supplied with the following isolating switches located and accessible from behind the case front door:

- SWBATT batteries
- SWMB manual by pass
- SWIN input
- SWBYP separate emergency mains input (optional)
- SWOUT output

9 – COMMUNICATION

COMMUNICATION PORTS

The rear panel (see UPS rear view) provides access to the following communication ports:

- Serial port, available with RS232 connector and USB connector.
NOTE: the use of one connector automatically excludes the other.
- Expansion slot for additional slot-in communications interface cards

Behind the front terminal panel, a further expansion slot is available for a volt-free signal card (optional 250Vac, 3A, 4 programmable contacts).

RS232 AND USB CONNECTORS

RS232 Connector

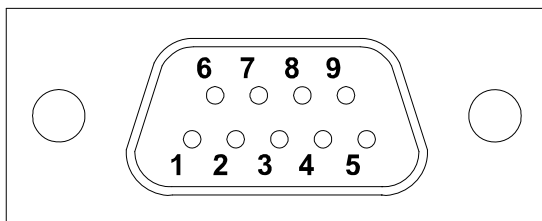

USB Connector

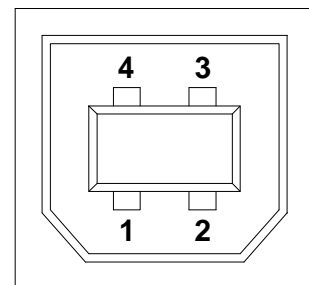

PIN #	NAME	TYPE	SIGNAL
1		IN	
2	TX	OUT	TX serial line
3	RX	IN	RX serial line
4			
5	GND	POWER	
6		OUT	
7			
8	+15V	POWER	Isolated power supply 15V±5% 80mA max
9	WKATX	OUT	ATX power supply wake-up

PIN #	SIGNAL
1	VBUS
2	D-
3	D+
4	GND

COMMUNICATION SLOTS

The UPS has two panel expansion slots for slot-in interface accessories that can be used for a variety of communications options including:

- Second RS232 port
- Serial port duplicator
- Ethernet network agent with TCP/IP protocol, HTTP and SNMP
- RS232 + RS485 port with JBUS/22#MODBUS protocol

For further accessory information please visit our website.

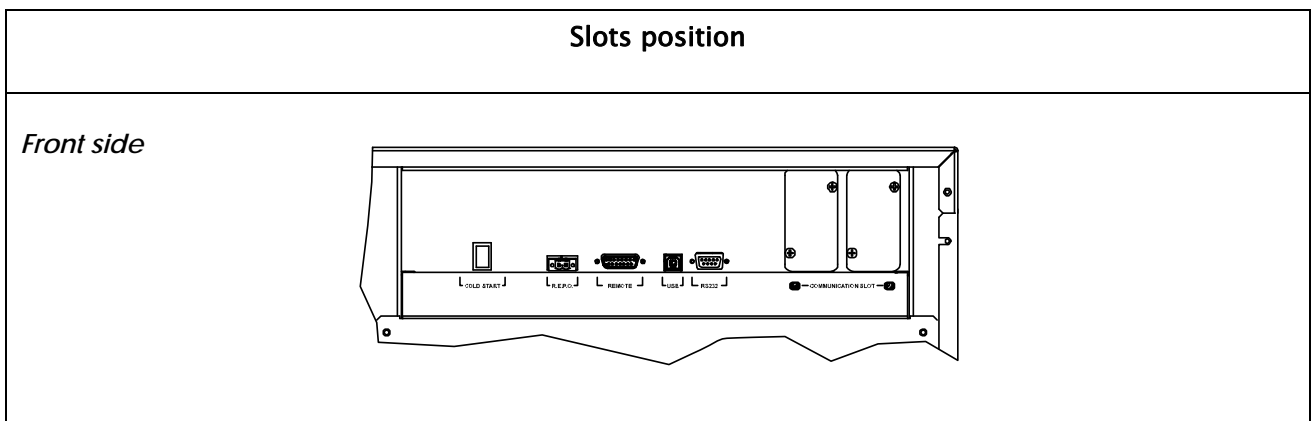

AS400 PORT

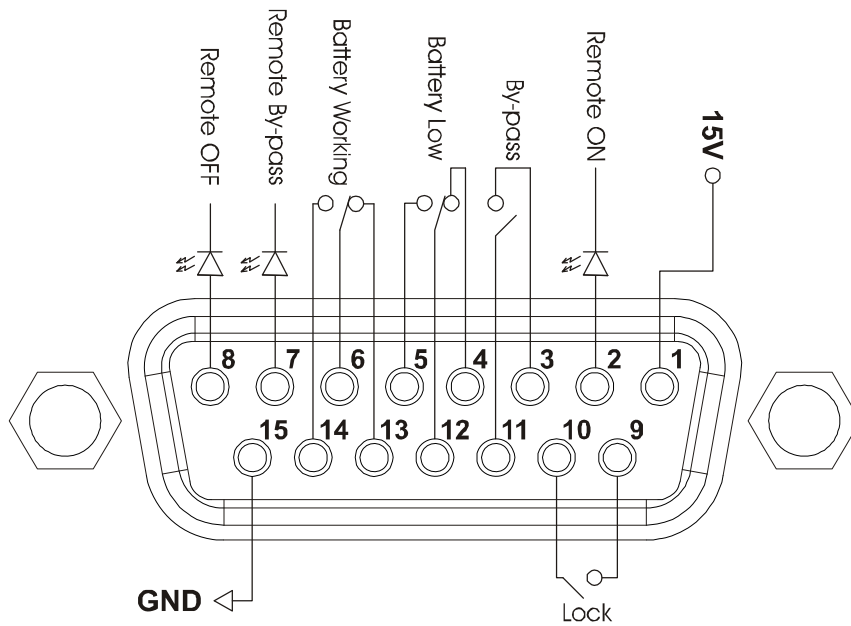

PIN #	DESCRIPTION	TYPE	FUNCTION
1	15V	POWER	Isolated auxiliary power supply +15V± 5% 80mA max
15	GND	POWER	Ground for the isolated auxiliary power supply (15V) and remote controls (Remote ON, Remote BYPASS, Remote OFF)
2	REMOTE ON	INPUT #1	By connecting pin 2 with pin 15 for at least 3 seconds the UPS switches on
8	REMOTE OFF	INPUT #2	By connecting pin 8 to pin 15 the UPS is shut down immediately
7	REMOTE BYPASS	INPUT #3	By connecting pin 7 to pin 15 the load power supply switches from inverter to bypass. For as long as the connection is made, the UPS continues to operate on bypass even if the input mains supply fails. If the jumper is removed with the mains power supply present, the UPS will resume operation and the load will be powered by the inverter. If the jumper is removed with the mains power supply fails, the UPS will resume operation on battery power.
4,5,12	BATTERY LOW	OUTPUT #1	Reports that the batteries are at the end of discharge when contact 5/12 is closed ⁽¹⁾
6,13,14	BATTERY WORKING	OUTPUT #2	Reports that the UPS is operating on battery power when contact 6/14 is closed
9,10	LOCK	OUTPUT #3	When the contact is closed, reports that the UPS is blocked ⁽¹⁾
3,11	BYPASS	OUTPUT #4	When the contact is closed, reports that the bypass supply is powering the load

NOTE: The diagram shows the contacts present inside the UPS that can provide a maximum current of 0.5A at 42Vdc. The position of the contacts in the diagram is shown without alarms or warnings.

⁽¹⁾ The output can be programmed through the appropriate configuration software. The function shown is the default (configured by the manufacturer).

> 9.1 EMERGENCY SHUTDOWN (R.E.P.O.)

This isolated input is used to switch off the UPS in an emergency. The UPS is supplied with the "Remote Emergency Power Off" (R.E.P.O.) terminals short circuited. At installation, remove the short-circuit and connect to the normally closed contact of the shutdown device, using a double-insulating cable.

When activated from a remote push-button or other device in an emergency, the R.E.P.O connection opens and the UPS switches to stand-by mode. The UPS no longer powers the load.

The R.E.P.O circuit is supplied with SELV type circuits. No external supply voltage is required. When it is closed (normal condition), a maximum current of 15mA flows.

After an emergency shutdown, the UPS will return to on-line operating mode only when it receives a startup command from the mimic panel (provided that the Remote Emergency Power Off device is not still active).

> 9.2 EXTERNAL SYNCHRONISATION

This non-isolated input can be used to synchronise inverter output with a suitable signal from an external source. It is essential when the **SafepowerEvo-HF** is used in combination with Static Switch Transfer Systems.

At installation, it is important to:

- use an isolation transformer with isolated single-phase output (SELV), 12-24ac and power = 0.5VA
- connect the transformer secondary to the "EXTERNAL SYNC" terminal through a double-insulation cable with cross-sectional area of 1 sq.mm.

After installation, UComGP can be used to configure and control this feature.

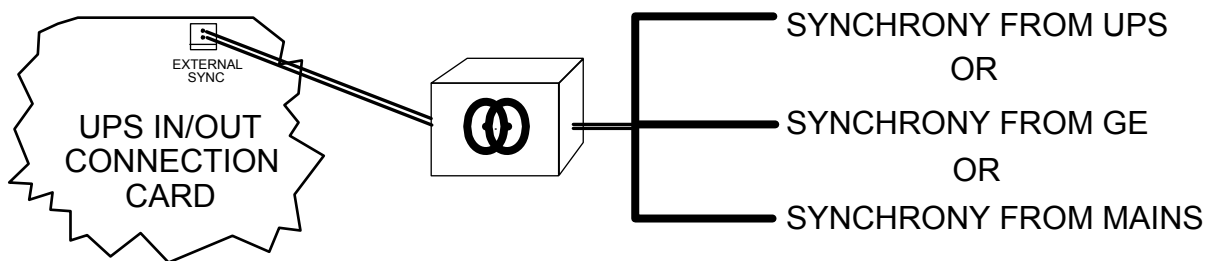

> 9.3 MONITORING AND CONTROL SOFTWARE

The UPS is supplied with UPS MON monitoring and control software to provide the following:

- Chronological event recording
- UPS operating status management
- E-mail, modem, SNMP agent support
- Sequential shutdown and load-shedding within a network environment

> 9.4 CONFIGURATION SOFTWARE

The UComGP software package allows complete UPS configuration through an RS232 serial port, In the table overleaf:

CP (Control Panel)=Shows that the configuration can be modified using UComGP or the front control panel.

SW (Software)=Shows that this configuration can be only modified through UComGP.

FUNCTION	DESCRIPTION	PRESET	POSSIBLE CONFIGURATIONS	MOD.
Output frequency	Selection of the output nominal frequency	Auto	50 Hz • 60 Hz • Auto: automatically selected from the input frequency	CP
Output voltage "Phase - Neutral"	Selection of the output nominal voltage	230V	• 200V • 208V • 220V • 230V • 240V • 220 to 240 in steps of 1V (only through software)	CP
Modes of operation	Selection of one of the 4 different operating modes	ON LINE	• ON LINE • ECO • SMART ACTIVE • STAND-BY OFF • FREQUENCY CONVERTER (only through software)	CP
Auto restart delay	Delay time for UPS automatic switching-on after the mains is restored	5 seconds	Disabled • 1 to 255 in steps of 1 second	CP
Power Walk In	Starts the ramp return mode from the mains	Disabled	Enabled Disabled	SW
Power Walk In Start Delay	Setting of the delay time for starting of rectifier after the mains is restored (always enabled)	0 s	1 to 120 in steps of 1 second	SW

FUNCTION	DESCRIPTION	PRESET	POSSIBLE CONFIGURATIONS	MOD.
Power Walk In Duration	Setting of the ramp duration when the mains is restored (only if Power Walk-In is enabled)	10 seconds	1 to 120 in steps of 1 second	SW
Shutdown due to minimum load	Automatic shutdown of the UPS when battery-operated, if the load is lower than 5%	Disabled	Enabled • Disabled	CP
Back-up time limit	Maximum time on battery-operation	Disabled	Disabled (batteries totally discharged) • 1 to 65000 in steps of 1s	SW
End of discharge pre-alarm	Estimated remaining back-up time before end of discharge pre-alarm	3 minutes	1 to 255 in steps of 1 minute	SW
Battery Test	Time range for the automatic testing of the batteries	40 hours	Disabled • 1 to 1000 in steps of 1 hours	SW
Alarm threshold for maximum load	Selects the user limit for overload	Disabled	Disabled • 0 to 103 in steps of 1%	SW
Buzzer	Selects the buzzer mode operation	Limited	Normal • Limited: does not sound for temporary bypass operation	CP
Auxiliary Socket (power share)	Selects the operating mode for the auxiliary socket	Always connected	Always connected • Disconnected after n seconds of battery operation • Disconnected after n seconds from the end of discharge pre-alarm • ... (see UComGP manual)	SW
Battery expansion	Setting of the Ah installed (expansion of the external battery)	0 Ah	Min.: 0 - Max.: 999 (in steps of 1 unit)	CP
Language	It selects the display language	English	<ul style="list-style-type: none"> • English • Italian • German • French • Spanish • Polish • Russian • Chinese 	CP
Advanced Functions				
Input frequency tolerance	Selects the admitted input frequency range for the bypass transfer and output synchronization	± 5%	± 0.25% • ± 0.5% • ± 0.75% • 1 to 10 in steps of 1%	SW
Bypass voltage thresholds	Selects the permissible voltage range for bypass transfer	Low:180V High:264V	Low:180 to 200 in steps of 1V High: 250 to 264 in steps of 1V	SW
Bypass voltage thresholds for ECO	Selects the permissible voltage range for ECO operating mode	Low:200V High:253V	Low:180 to 220 in steps of 1V High: 240 to 264 in steps of 1V	SW
Action sensitivity for ECO	Selects the operation sensitivity during ECO mode operation	Normal	Low • Normal • High	CP

Load power supply in stand-by	Load power supply on bypass with UPS off (stand-by state)	Disabled (load NOT powered)	Disabled (not powered) • Enabled (powered)	SW
Bypass operation	Selects the operating mode of the bypass line	Enabled / High sensitivity	Enabled / High sensitivity • Enabled / Low sensitivity • Disabled with input / output synchronisation • Disabled without input / output synchronisation	SW
Inverter synchronisation (External Sync)	Selects the synchronisation source for the inverter output	From bypass line	From bypass line • From external input	SW
Inverter synchronisation speed at the bypass line	Selects the inverter synchronisation speed at the bypass line	1 Hz/second	0.5 Hz/second • 1 Hz/second • 1.5 Hz/second • 2 Hz/second	SW
External temperature probe (optional)	Enables reading of the external temperature probe	Not enabled	Not enabled • Enabled	SW
Batteries configuration				
Battery custom voltage and current thresholds	Recharging voltage	±286 V	±260 ÷ ±300 V	SW
	Floating voltage	±273 V	±260 ÷ ±300 V	
	Battery low voltage	±220 V	±210 ÷ ±240 V	
	End discharge voltage	±204 V	±190 ÷ ±230 V	
	Recharging current	12 %	3 ÷ 50 %	

* Setting these output voltage values will lead to the reduction of the output power of the UPS (see "Reducing the load (at 200V and 208V) paragraph")

** Pressing the F1 and F4 keys at the same time for $t > 2$ sec will automatically reset English as the language.

10 – UPS CABINET

The cabinet is made of galvanised steel with an IP20 rating (degree of Ingress Protection), even with the front door open.

Ventilation via the rear panel; air intake is front to rear.

The main assemblies (including the power module and magnetics) are temperature monitored.

11 – OPTIONS

> 11.1 COMMUNICATION

PowerNETGuard is a centralised UPS management and control software package using the SNMP communications protocol. It is the ideal UPS management tool for IT/EDP managers running datacenters and medium-to-large-sized networks.

The main features of the software include:

- Various display levels by geographical areas, building plans, maps.
- Multi-user accesses with various security levels.
- Compatible with RFC 1628 standard SNMP agents.
- Graphical representation and file backup of operating measurements
- Notification of alarms via email and SMS.
- Integrated Wap Server for display of alarms.
- Suitable for operation with Windows operating systems: (98, ME, NT, 2000, 2003, and Xp) Linux, Mac OS X, Solaris 8 and 9.

Hardware

Two slots are available in which to house one or two of the following options:

- a) **NetMan 102 Plus:** the NetMan Plus network agent allows UPS management across a LAN using any of the main network communication protocols - TCP/IP, HTTP and network interface (SNMP). NetMan Plus enabled UPS integrate easily into medium and large sized networks and provide reliable communications between the UPS and management systems employed.
- b) **MultiCom 302:** a Modbus/Jbus protocol converter through an RS232 or RS485 output for monitoring the UPS, for example, from a BMS (Building Management System). It also provides a second independent RS232 serial line that can be used by other devices such as a NetMan Plus or PC.
- c) **Multicom 382:** it provides a set of relay contacts to provide UPS alarm and status indication. The contacts are connected through terminal connections. Signal contacts include Emergency Power Off (EPO), Remote Shut Down (RSD), On Battery, On Bypass, Alarm and Low battery. The contacts are change over or normally open.
- d) **Multicom 372:** MultiCOM 372 provides a UPS with an additional RS232 serial interface port. The card has Emergency Power Off (EPO) and Remote Shut Down (RSD) inputs with terminal connections.
- e) **Multi Panel:** MultiPanel is a remote monitoring device that can provide a detailed UPS status overview in real time. It is compatible with all Siel UPS and can display values for UPS specific input and output supplies, and battery set measurements. MultiPanel has a high-definition graphical display and can report in many languages: English, Italian, German, French, Spanish, Polish, Russian, Chinese and Turkish. It has 3 independent serial ports, one of which allows for UPS monitoring via the MODBUS/JBUS protocol (on either an RS485 or RS232 serial line). The others can

be used with devices such as the Netman 101 Plus or a PC running PowerShield³ software.

> **11.2 EXTERNAL BATTERY TEMPERATURE SENSOR**

The UPS has a special entry point for measuring the temperature inside a remote Battery Box and indicating the temperature on the UPS display.

The specific kit supplied by the manufacturer includes a bipolar double isolated cable measuring 6 meters. The use of a bipolar cable without isolation exposes the UPS and the user to risks resulting from a lack of isolation as the reading refers directly to the UPS neutral earthing.

Once installed, the device is configured using the UComGP software package supplied on the CD-ROM with the UPS.

> **11.3 EXTERNAL MAINTENANCE BYPASS**

An external remote maintenance bypass can be installed with the UPS, to allow, for example, UPS replacement without disruption to the load.

If this option is chosen, it is essential to connect the "SERVICE BYPASS" terminal located inside the UPS to the auxiliary "Normally Open "(NO) contact of the SERVICE BYPASS switch. Operation of the SERVICE BYPASS switch closes this auxiliary contact and informs the UPS. If such a connection is not made, operation of the remote maintenance bypass may disrupt the supply of power to the load and damage the UPS.

Note: Always check that the remote maintenance bypass installation (if selected) is compatible with any transformer options selected for the UPS - see paragraph 11.6 Optional Transformer.

> 11.4 BATTERY CABINETS

THIS IS AN OPTIONAL ACCESSORY. The battery cabinet can be used to extend an internal battery set runtime or provide an external battery set when the space within the UPS for an internal battery is populated with extended runtime chargers or transformer options.

The number of batteries housed within the cabinet varies according to UPS rating. It is therefore necessary to carefully match that Battery Cabinet DC rating to that of the UPS.

The Battery Cabinet configuration is shown below.

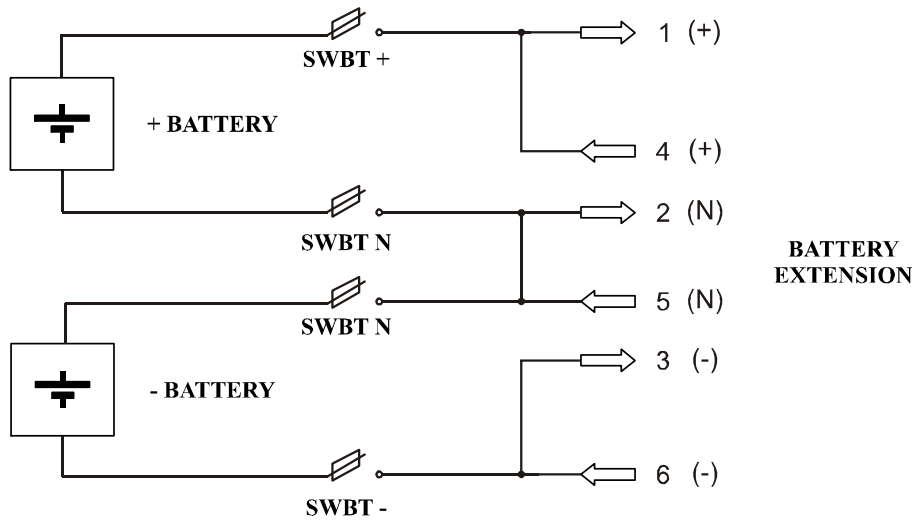

Some solutions that have been studied and are available in the catalogue for the 10-40kVA range are described below.

Other solutions may be developed on site, bearing in mind that:

- the structure of the battery enclosure must respect that described above.
- the number of batteries must remain constant (20+20 12 volt monoblocks)
- the battery capacity (expressed in AH) must fall within the range of 4 and 20 times the available recharging current (see the "technical specifications table")

Battery Box 10-40: (can be used on the entire range from 10 to 40 KVA)

BATTERY BOX MODELS	AB 1320-40B AB 1320-80B AB 1320-120B	AB 1900
--------------------	---	---------

Dimensions (mm)

H x W x D

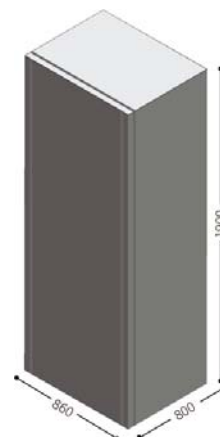
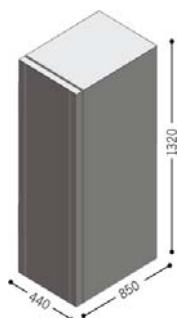

Model	AB 1320-40B	AB 1320-80B	AB 1320-120B	AB 1900
Weight	200Kg (90 empty)	300Kg (90 empty)	400Kg (90 empty)) 200 empty

> 11.5 ADDITIONAL BATTERY CHARGER

MST 10-40 & MSM 10-20 versions

The UPS can be furnished from the factory with a more powerful battery charger mounted in place of the standard one.

It is possible also the replacement of the standard battery charger directly on site using the appropriate on site installation kit (NOT FOR MST 30-40).

Model	10-12-15-20 KVA	30-40 KVA
Standard battery charger	6 Amperes	10 Amperes

> 11.6 OPTIONAL TRANSFORMERS

A transformer can be installed within the UPS battery compartment (removing the potential for an internal battery set). Transformer options include: supply neutral reference, Galvanic isolation and output voltage (step-up or down).

a) Transformer located inside the UPS (this option is only factory-installable)

The optional internal transformer is connected to the output to guarantee galvanic isolation both during inverter and bypass operating modes.

A Star-Star type transformer is used which does not induce phase displacement between the input and output; the neutral of the secondary is not earthed hence making the UPS suitable for TT, TN and IT connections.

b) Transformer located outside the UPS (depending on the requirements and the type of electrical set up described below).

This option can be applied to the entire 10-40KVA range

Note: An internal transformer will modify the neutral arrangements of the installation. Therefore, a "remote maintenance bypass" cannot be installed with the UPS if the UPS has an internal transformer.

If a remote maintenance bypass is installed, during its operation, to fully isolate the UPS (from its installation) open the UPS input/output isolating switches.

ELECTRIC CONNECTIONS DIAGRAMS

Note: An external transformer will modify the neutral arrangements of the installation. Therefore, if a "remote maintenance bypass" is installed it must be sited downstream of the transformer (for an input-side transformer) or upstream (for an output-side transformer).

UPS with Galvanic isolation on the input

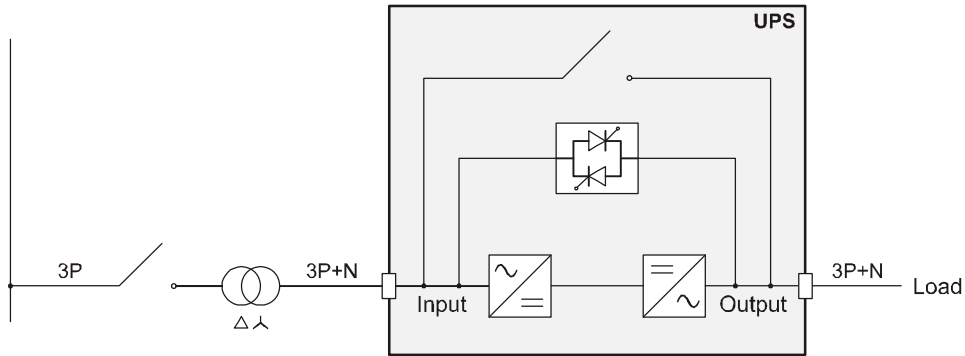

UPS with Galvanic isolation on the output

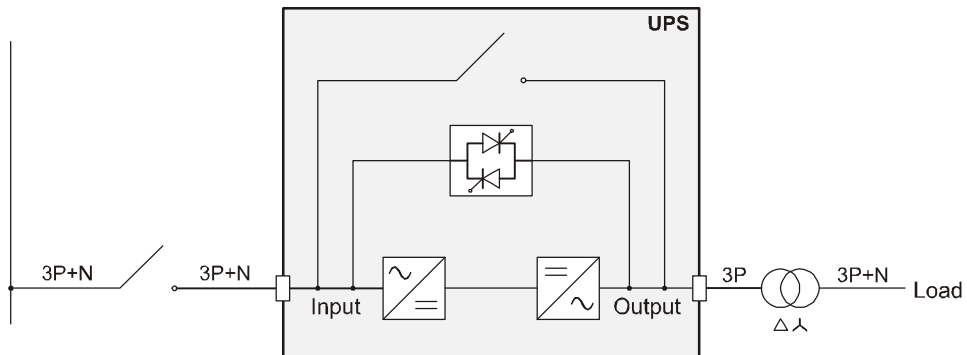

Separate bypass supply input from a common mains or alternative power supply:

UPS without variation of the neutral arrangements and with a separate bypass supply input (option)

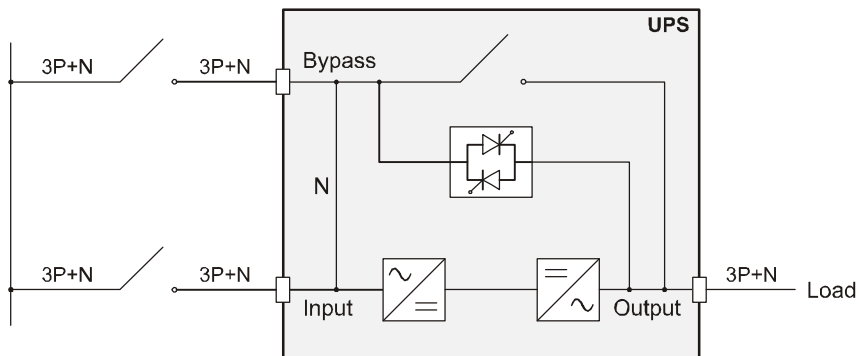

UPS with Galvanic isolation on the input-side and separate bypass supply input (option)

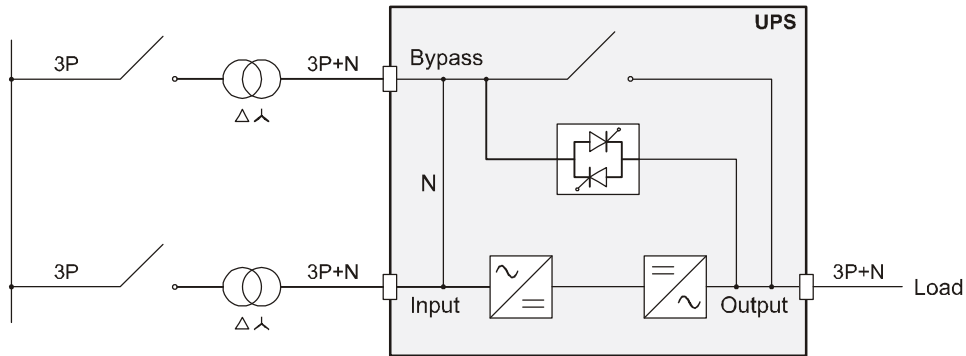

UPS with Galvanic isolation on the output-side and separate bypass supply input (option)

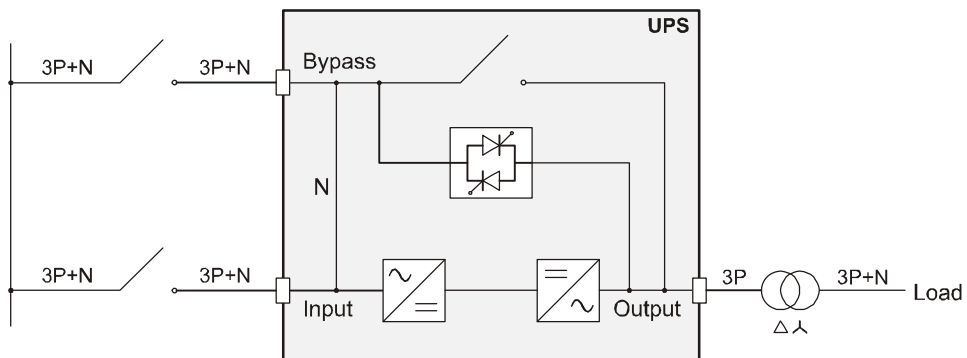

Separate bypass on separated lines upstream:

If the separate bypass option is present, the protection devices will be installed both on the mains supply line and on the separate bypass line.

Note: the neutral of the input line and that of the bypass are joined inside the equipment, therefore they will refer to the same potential. If the two mains supplies are different, it is necessary to use an isolation transformer on one of the inputs.

UPS without variation of the neutral arrangement and with a separate bypass supply (option) connected on the independent mains line

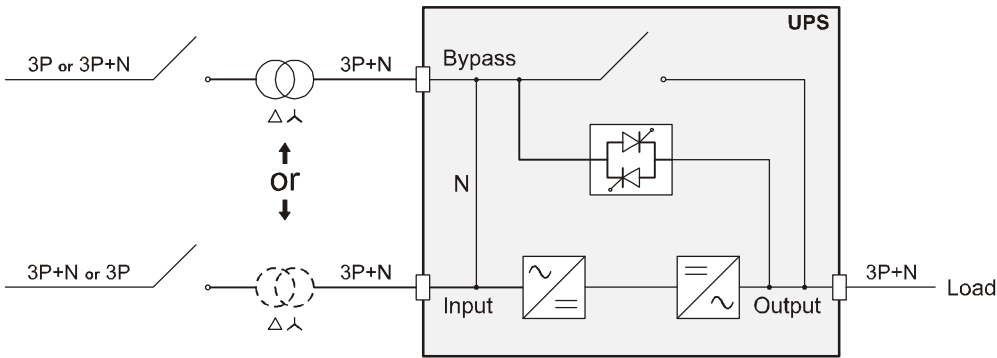

UPS with a separate bypass supply (option) connected to an independent supply and with galvanic isolation on the input

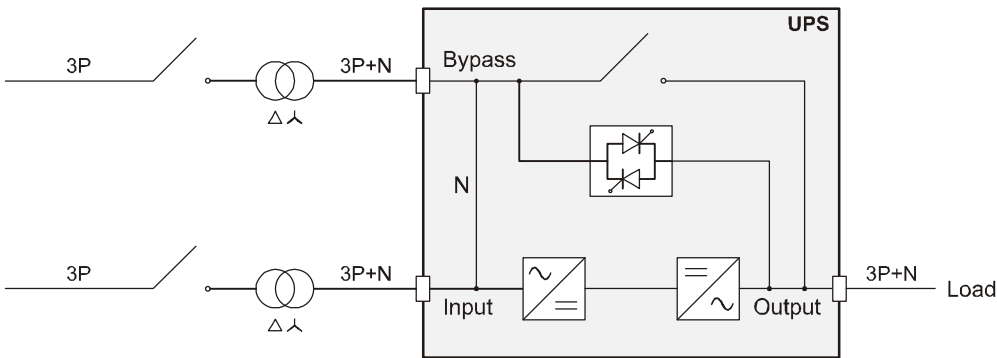

UPS with a separate bypass supply (option) connected to an independent mains supply and with galvanic isolation on the output

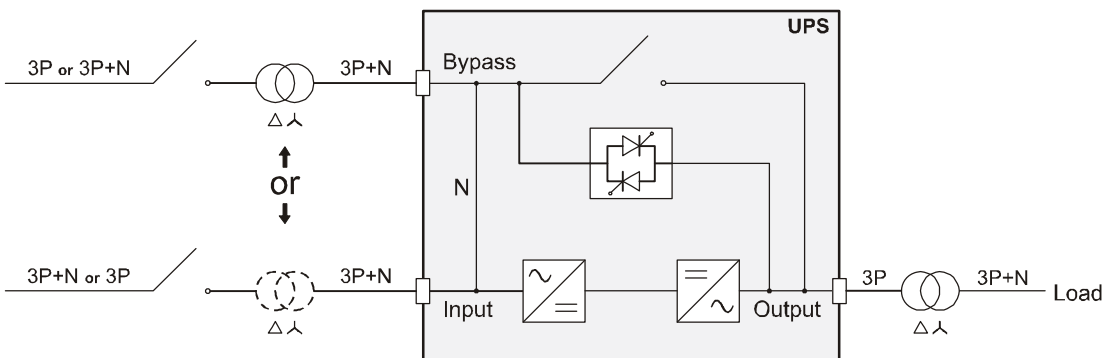

> 11.7 SEPARATE LINE INPUT

All the UPS versions in the range of 10-40 KVA models can be provided with input from the separate bypass line. This configuration can only be carried out in factory.

12 – ENVIRONMENTAL CONDITIONS

Room ambient temperature	0 to 40° C
Maximum temperature for 8 hours a day	40° C
Average temperature over 24 hours	35° C
Recommended working temperature for optimum battery performance	20 to 25° C
Storage temperature	- 25° up to +55 °C (UPS) - 15° up to +40 °C (UPS with battery)

13 – TECHNICAL DATA 10–40 KVA THREE-PHASE OUTPUT

Mechanical Characteristics	UPS Power (kVA)				
	10	15	20	30	40
Dimensions (mm)					
<ul style="list-style-type: none"> • Width MCT/MST • Depth MCT/MST • Height MCT/MST 	320/ 440 840/ 850 930/1320			440 850 1320	
Maximum weight with batteries inside (Kg) MCT/MST	180Kg 305Kg	190Kg 315Kg	195Kg 320Kg	335Kg	335Kg 345Kg
Ventilation	Forced through internal fans				
Cabinet IP rating	20				
Cable input	From the bottom/On the rear				
Colour	RAL 7016				

Electrical data	UPS Power (kVA)				
	10	15	20	30	40
INPUT					
Nominal voltage	380-400-415 Vac Three-Phase plus neutral				
Input Current ⁽¹⁾	20	29	38	54	70
Voltage range (without switching to battery power)	320 to 480 V at 100% of the load 240 to 480 V at 50% of the load				
Nominal frequency	50 or 60Hz				
Input frequency tolerance	40 to 72Hz				
Total Harmonic distortion (THDi) and power factor with full load	THDi ≤ 3 % , 0.99 pF				
Rectifier progressive start-up (Power Walk-in duration)	Programmable from 5 to 30 seconds in steps of 1 second (this function is disabled by default)				
Delayed switching	Programmable from 1 to 255 seconds in steps of 1second. (5 seconds by default)				

⁽¹⁾ The input current is stated for the following general conditions:

- Output load at 0.9pF
- Input voltage at 346 Volts
- A 4A (10-20) 7A (30-40) battery charger

Electrical data	UPS Power (kVA)				
	10	15	20	30	40
DC BUSBAR AND BATTERY SET					
Number of battery cells	120+120				
Float voltage (2.27 V/el. adjustable)	273+273 Vdc				
Boost voltage (2.4 V/el. adjustable)	288+288 Vdc				
End of discharge voltage – load dependent (1.6 V/el. adjustable)	192+192 Vdc				
Standard battery charger ⁽²⁾	Nominal 6 Amps			Nominal 10 Amps	
• Full load	4 A	4 A	6 A	7 A	
• 95% load	5 A	6 A	9 A	10 A	
• 90% load	6 A	6 A	10 A	10 A	

⁽²⁾ The currents refer to input voltages ≥ 200Volt

Electrical data	UPS Power (kVA)				
	10	15	20	30	40
INVERTER					
Nominal power (kVA)	10	15	20	30	40
Active power pF 0.9 (kW)	9	13.5	18	27	36
Active power with load power factor from 0.8 inductive to 0.9 capacitive (kW).	9	13.5	18	27	36
Nominal voltage	380/400/415 Vac Three-Phase plus neutral				
Derating for output voltage (Phase – Neutral) set to:					
• 208 V	- 5 %				
• 200 V	- 10 %				
Nominal frequency	50 / 60Hz				
Static stability	± 1%				
Dynamic stability	± 3% (1) (resistive load) EN62040-3 class performance 1 distorting load				
Recovery Time within ± 1%	20ms In compliance with standard EN 62040-3, class 1				
Crest factor (I _{peak} /I _{rms} as per EN 62040-3)	3:1				
Voltage distortion with linear load (EN 62040-3)	= 1% with linear load = 3% with distorting load				
Frequency stability without Inverter and by-pass supply synchronisation	0,01%				
R _{rate} of Frequency variation	1Hz/sec (adjustable from 0.5 to 2)				
Voltage phase Dissymmetry with balanced and unbalanced loads	± 1% / ± 2%				
Voltage phase shift with balanced and unbalanced loads	120 ± 1 °				
Inverter overload	>100% ÷ ≤110% 10 min. >110% ÷ ≤133% ÷ 1 min. >133% ÷ ≤150% 5 sec. >150% 0,5 sec.				
Short circuit current	1.5 x I _n for t=500 ms				
Efficiency on battery-operation	≥92,5%	≥93,5%		≥95,3%	

(1) @ Mains / battery / mains @ resistive load 0% / 100% / 0%

Electrical data	UPS Power (kVA)				
	10	15	20	30	40
BY-PASS					
Nominal voltage	380-400-415 Vac Three-Phase plus neutral				
Output nominal current (A)	15	22	29	43	58
Bypass voltage range	from 180V (adjustable 180-200) to 264 V (adjustable 250-264V)				
Nominal frequency	50 to 60Hz				
Bypass input frequency range	± 5% (adjustable from 0.25 to 10%)				
Transfer time from By-pass to Inverter (UPS in "ECO mode")	2 ms typical				
Transfer delay to Inverter from By-pass	4 sec				
Overload capability on bypass line	<ul style="list-style-type: none"> • ≤ 110% infinito • > 110% ÷ ≤133% 60 min. • > 133% ÷ ≤150% 10 min. • > 150% 2 sec. 				

Electrical data	UPS Power (kVA)				
	10	15	20	30	40
SYSTEM					
AC/AC Efficiency (On line)					
Full load	93,5	94,0	94,0	96,1	96,0
75% Load	93,0	93,8	94,0	96,2	96,2
50% Load	91,8	93,0	93,8	96,1	96,2
25% Load	89,3	91,6	91,6	95,0	95,7
Auto-consumption (W)	220	240	240	240	240
Efficiency with UPS in STAND BY mode	≥ 98 %				
Audible noise at 1mt (from 0 to full load) - (dBA)	≤ 48 dB (A)	≤ 52 dB (A)		≤ 48 dB (A)	
Operating temperature	0 ± 40 °C				
Max. relative humidity during operation	90% (without condensation)				
Max. installation altitude	1000 m at nominal power (- 1% reduction in power for every 100m over 1000m) Max 4000m				
Power dissipated with resistive nominal load (pf=0.8) and backup battery*	0.63 kW 540 kcal/h 2150 B.T.U./h	0.86 kW 740 kcal/h 2940 B.T.U./h	1.15 kW 990 kcal/h 3930 B.T.U./h	1.10 kW 946 kcal/h 3755 B.T.U./h	1.50 kW 1290 kcal/h 5120 B.T.U./h
Power dissipated with distorting nominal load (pf=0.7) and charged battery *	0.49 kW 420 kcal/h 1670 B.T.U./h	0.67 kW 580 kcal/h 2290 B.T.U./h	0.90 kW 775 kcal/h 3070 B.T.U./h	0.990 kW 852 kcal/h 3380 B.T.U./h	1.35 kW 1161 kcal/h 4610 B.T.U./h
Fan capacity in installation room for dissipating heat **	340 mc/h	460 mc/h	615 mc/h	587 mc/h	800 mc/h
Max current leaked to earth ***	≤ 5 mA			≤ 50 mA	

*3.97 B.T.U. = 1 kcal

**To calculate air capacity the following formula can be used: $Q \text{ [mc/h]} = 3,1 \times P_{\text{diss}} \text{ [Kcal]} / (t_a - t_e) \text{ [°C]}$

P_{diss} is the power dissipated by the UPS (expressed in Kcal) within the installation environment.

t_a = room temperature, t_e = external temperature. 10% must be added to the derived figure to take into account system losses. In the above table an example is shown of capacity with $(t_a - t_e)=5^\circ \text{C}$ and a resistive nominal load (pf=0.9).

PS: This formula can be applicable if $t_a > t_e$; otherwise, the installation will require air conditioning.

***The dispersion current of the load is added to that of the UPS on the ground protection conductor.

e-mail: info@sielups.com
www.sielups.com

